

FX20 High- Speed Counting Module User Manual



CONTENT

1. Product Introduction	2
2. Version change records	2
3. Regarding manual acquisition.....	2
4. Warranty Statement	2
5. FX20 introduction to Dual Channel High Speed Counting Module	3
5.1. Introduction to Appearance and Function.....	3
5.2. Technical data.....	4
5.3. Dimension drawing	5
6. Mechanical installation and disassembly	6
6.1. Installation location and minimum installation distance.....	6
6.2. FX20 adapter installation	6
6.3. I/O modules installation.....	6
6.4. Modules disassembly.....	7
7. Electrical installation and wiring.....	8
7.1. Cable specification	8
7.1.1. Communication cable	8
7.1.2. Power and signal cables.....	8
7.2. Modules wiring diagram	10
7.2.1. FX20 system power supply diagram	10
7.2.2. Definition of high-speed counting module terminals	10
8. Configuration and debugging	11
8.1. Debugging in Siemens PORTAL	11
8.1.1. Configuration steps.....	11
9. Fault diagnosis	21
Appendix	22

1. Product Introduction

The FX20 series high-speed counting module adopts a dual channel design, and each channel supports multiple counting modes of phase A, B, and Z, with forward and reverse counting functions. The maximum counting frequency is 500KHz, and it supports multiple types of high-speed pulse signals, including source, drain, and push-pull. At the same time, each channel is equipped with a pair of DI/DO signal points, which can easily set control logic such as overspeed alarm and counting reset.

Product features:

- High measurement accuracy
- Fast response speed
- Supports counting and frequency doubling
- Maintain the value of the power outage meter

The FX20 high-speed counting module is suitable for application scenarios such as motor speed measurement, servo control, and grating ruler measurement, providing a cost-effective IO comprehensive solution for industries such as metallurgy and machine tools.

2. Version change records

Revision date	Version	Change content
2024-4	V1.0	First edition manual release
2025-12	V2.0	Update fonts and layouts

3. Regarding manual acquisition

This manual is not shipped with the product. If you need to obtain an electronic PDF file, you can obtain it through the following methods:

- Log in to the official website of ELCO (www.elcoautomation.com), search for keywords, and download.
- Use WeChat to search and follow the official account of "ELCO Automation" to obtain the product manual.
- Contact the sales engineer of ELCO Automation in your region to obtain the latest manual materials.

4. Warranty Statement

Under normal use, if the product malfunctions or is damaged, ELCO Automation is responsible for an 18 months warranty (from the date of manufacture, the delivery date shall prevail, and any contractual agreements shall be executed in accordance with the agreement). If it exceeds 18 months, maintenance fees will be charged.

Within 18 months, repair fees will be charged for product damage caused by the following circumstances.

- Failure to operate this product according to the instructions in the manual, resulting in product damage.
- Damage to products caused by fires, floods, and abnormal voltage.
- Using this product for abnormal functions may cause product damage.
- Damage to the product caused by exceeding the specified usage range.
- Secondary damage to products caused by force majeure factors such as natural disasters, earthquakes, and lightning strikes.

The service fees shall be calculated according to the unified standards of ELCO. If there is a contract, the principle of contract priority shall be applied.

5. FX20 introduction to Dual Channel High Speed Counting Module

5.1. Introduction to Appearance and Function

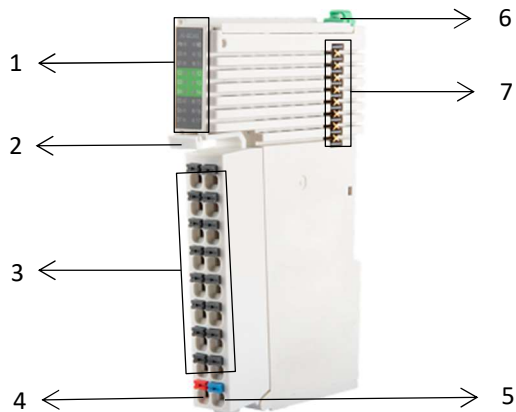

No.	Items	Function	Status
1	Running Indicators		
	PW	Module power supply indicator light	Green: normal; Red: module power supply undervoltage, overvoltage; Off: No power supply to the module;
	MD	Module status indicator light	Green light: normal; Green flashing: Connected, not configured; Flashing red and green alternately: not connected; Red: Counter error
	EN1, EN2	Channel1 or 2 Enable	Green: enable; Off: Not enabled
	A1, B1, Z1 A2, B2, Z2	Channel1 or 2 Data receiving	Green: Data available; Off: No data
	UP1, UP2	Channel1 or 2 Forward Counting	Green: Counting Forward
	DN1, DN2	Channel1 or 2 Reverse counting	Green: Counting Reverse
	DI1, DI2	Channel1 or 2 Digital input	Green: DI ON
	DO1, DO2	Channel1 or 2 Digital output	Green: Do ON
2	Terminal disassembly buckle	Pressing the buckle can separate the wiring terminal block from the module	-
3	Encoder wiring terminals	Encoder signal wiring connection	-
00	A1	Channel1 A-phase signal input terminal	
01	B1	Channel1 B-phase signal input terminal	
02	Z1	Channel1 Z-phase signal input terminal	

03	24V	24V+, Power supply 24VDC	
04	GND	GND, Power supply 0V	
05	PE	Protective Earth	
06	DI1	Channel1 DI	
07	DO1	Channel1 DO	
20	A2	Channel2 A-phase signal input terminal	
22	B2	Channel2 B-phase signal input terminal	
22	Z2	Channel2 Z-phase signal input terminal	
23	24V	24V+, Power supply 24VDC	
24	GND	GND, Power supply 0V	
25	PE	Protective Earth	
26	DI2	Channel2 DI	
27	DO2	Channel2 DO	
4	24 V DC in	24 V+	-
5	0 V DC in	0 V	-
6	Module fixing buckle	Used to secure modules to standard DIN rails	Pulling up: installation position; Pressing down: locking position
7	Backplane bus interface	Backplane communication	-

5.2. Technical data

FX20-CNT-BB00

ARTICLE PROPERTIES

PRODUCT TYPE	FX20 series modular I/O system high-speed counting module	PRODUCT GROUP	IP20 modular I/O system
DESCRIPTION	FX20-submodul 2-channel high-speed counting module, 24 V DC, max. 500 Hz, IP20, DIN rail installation	PU	1 pc
		COUNTRY OF ORIGIN	CN

TECHNICAL DATA

NUMBER OF CHANNEL	2	COUNT COMPARISON FUNCTION	Yes
INTERFACE TYPE	Terminal type	FORWARD AND REVERSE COUNTING	Yes
ENCODER POWER SUPPLY TERMINALS	2 x 24 V DC	COUNTING ALARM FUNCTION	Yes
ENCODER INPUTS	A, B, Z three-phase, 24 V	FILTERING FUNCTION	0 ... 10 ms can be set
COUNTING MODES	B pulse mode, B pulse + A direction mode, A + B mode, A + B + Z mode	I/O CHANNELS	Input: 2 PNP / NPN Output: 2 PNP
COUNTING FREQUENCY	Max. 500 kHz	OPERATING VOLTAGE	24 V DC

ENCODER FREQUENCY DOUBLING MODE	x1, x2, x4	CURRENT CONSUMPTION (5 V)	60 mA
PROCESS DATA LENGTH	32 bits	FAULT DIAGNOSIS METHOD	LED, communication message
COUNTING RANGE	-2147483648 ... +2147483647		

CONNECTION DATA

WIRE CONNECTION	Plug-in terminal block	STRIPPED LENGTHS	8 ... 10 mm 0.315 ... 0.394 in
CROSS SECTION	0.08 mm ² ... 2.5 mm ² , AWG 28 ... 14		

ENVIRONMENTAL REQUIREMENTS

PROTECTION CLASS	IP20	ELECTRO-STATIC DISCHARGE (ESD)	Level A, per IEC 61000-4-2
MOUNTING TYPE	DIN-35 mm rail	SURGE TEST	Level A, per IEC 61000-4-5
AMBIENT TEMPERATURE	-5 ... +60 °C	VIBRATION RESISTANCE	4 g, per IEC 60068-2-6
STORAGE TEMPERATURE	-25 ... +70 °C	SHOCK RESISTANCE	15 g, per IEC 60068-2-27
RELATIVE HUMIDITY	95%, non-condensing	EU ROHS COMPLIANCE STATUS	Yes
OPERATING ALTITUDE	0 ... 2000 m / 0 ... 6562 ft	MATERIAL COMPLIANCE	Compliant with REACH
POLLUTION DEGREE	2, per IEC 61131-2	DIMENSIONS (H X W X D)	110.6 x 15 x 78.4 mm
ELECTRICAL FAST TRANSIENT (EFT)	Level A, per IEC 61000-4-4	CONFORMITY MARKING	CE

GENERAL DATA

HOUSING MATERIAL	PPE	DIMENSIONS (H X W X D)	110.6 x 15 x 78.4 mm
WEIGHT	63 g	APPROVALS	CE
COLOR	Light gray		

5.3. Dimension drawing

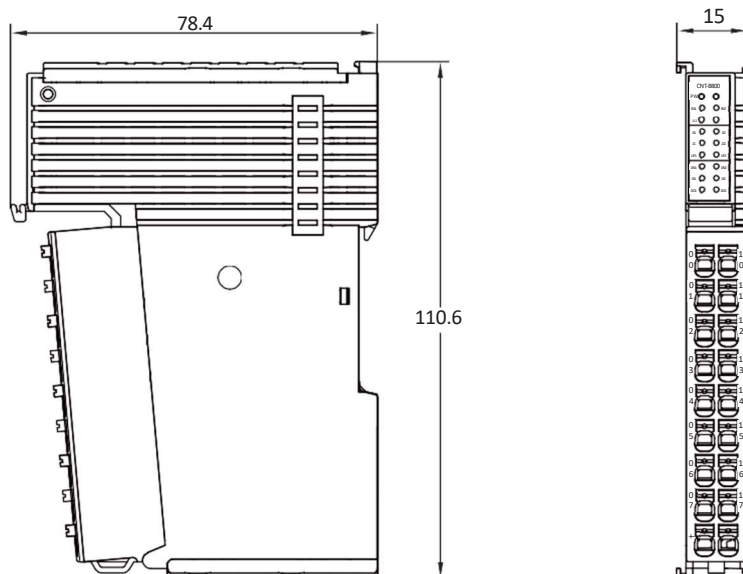

6. Mechanical installation and disassembly

6.1. Installation location and minimum installation distance

The installation position and reserved space are shown in the following figure. Install the installation guide rail horizontally to the designated installation position, and the connection surface of the connector and I/O modules must face forward.

The installation position should maintain a certain distance from adjacent electrical components or cabinets to facilitate heat dissipation. The recommended minimum installation clearance can refer to the markings in the above figure.

Ensure that FX20 is ventilated from bottom to top and achieve optimal cooling through convective ventilation.

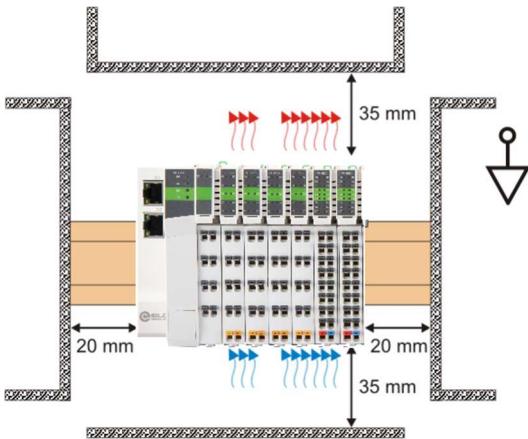

6.2. FX20 adapter installation

The installation is carried out according to the following steps:

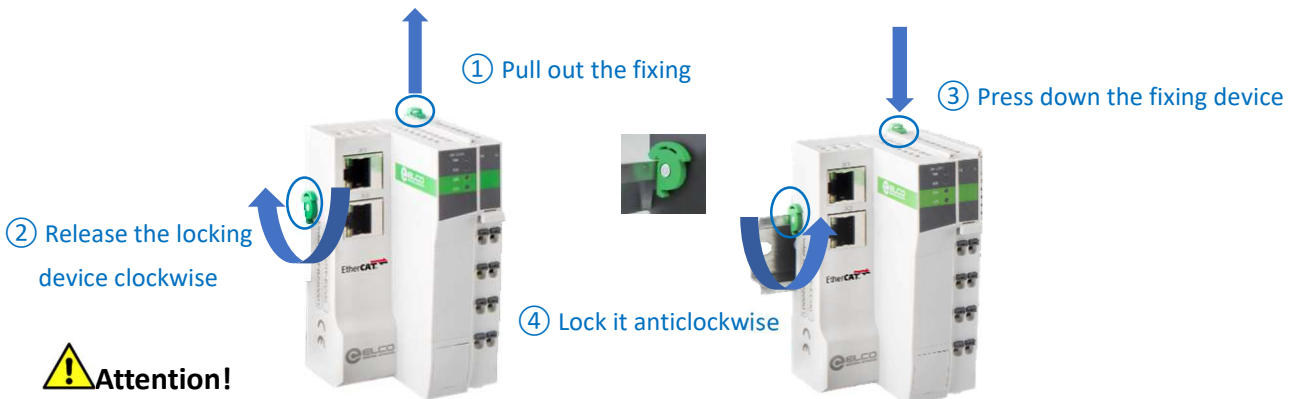

! Attention!

During installation, align the module with the DIN rail and press the fixing device in the direction indicated by the arrow. After installation, there will be a noticeable clicking sound; change the position of the locking device slightly; after installing the module properly, make the locking device clamp the upper edge of the rail; to avoid damaging the product, do not apply excessive force.

6.3. I/O modules installation

After the installation of the adapter, the function modules can be sequentially inserted from the right side of the adapter. Before the insertion, ensure to pull out the fixing device and aligned with the two slots on the module.



i Caution!

The end cover is only to protect the backplane bus interface of the end module, and it is packaged and shipped together with the adapter.

6.4. Modules disassembly

Use a flat screwdriver or similar tool to pry up the locking device on the rail, and then pull the module away from the DIN rail.



The wiring terminals of all modules can be removed separately to facilitate module replacement, as follows:

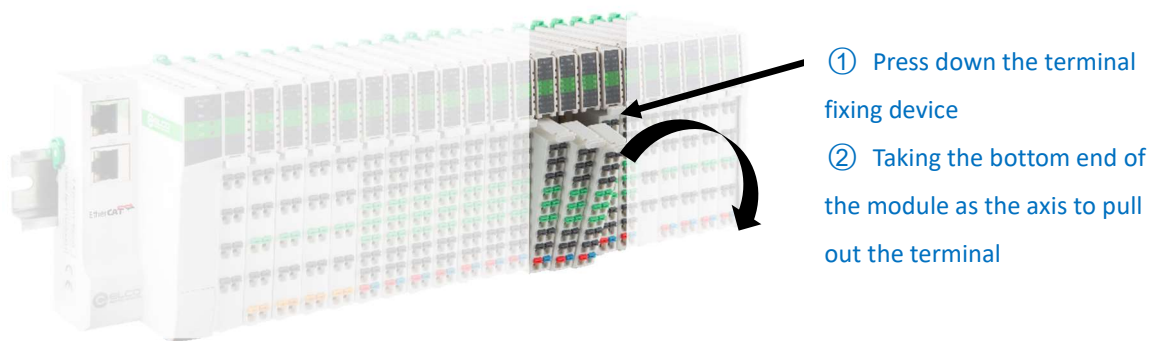

Warning!

The mechanical installation and disassembly of modules require qualified professional mechanical personnel to operate and pay attention to the correct wearing and use of labor protection equipment.

7. Electrical installation and wiring

7.1. Cable specification

7.1.1. Communication cable

FX20 bus adapter communication uses shielded network cables for data transmission, without short circuits, misalignment, and poor contact; The length of the cable between devices cannot exceed 100m, as exceeding this length will cause signal attenuation and affect normal communication. The following specifications of communication cables are recommended:

Item	Specification
Cable type	Elastic crossover cable, S-FTP, category 5
Standards met	EIA/TIA568A,EN50173,ISO/IEC11801 EIA/TIA bulletin TSB,EIA/TIA SB40-A&TSB36
Conductor section	AWG26
Wire type	Twisted pair
Wire pair	4

Pre-wired connectors are better for communication and construction. Elco pre-wired connectors can provide customized cable material and cable length in accordance with communication technology requirements. The following Elco Ethernet connectors are available:

Model	Description
E16DA4002M020	RJ45-M12 double-ended pre-wired Ethernet connector, male straight, D-CODE, 4-pin, Cat5e, PVC, 2 M, fixed installation
E66D04002M020	RJ45-RJ45 double-ended pre-wired Ethernet connector, male straight-male straight, 4-pin, Cat5e, PVC, 2 M, fixed installation
E16DA4004M020	RJ45-M12 double-ended pre-wired Ethernet connector, male straight, D-CODE,4-pin, Cat5e, PVC, 2 M, suitable for drag chain
E66D04004M020	RJ45-RJ45 double-ended pre-wired Ethernet connector, male straight-male straight,4-pin, Cat5e, PUR,2 M, suitable for drag chain

i For more selection of Ethernet connectors, please refer to Elco's "Connectivity System Catalog".

7.1.2. Power and signal cables

The FX20 series adopts tool-free spring wiring terminals, and the wiring needs to be equipped with tube type cold pressing cable lugs. Please refer to the following figure for the stripping length and cable lug specifications:

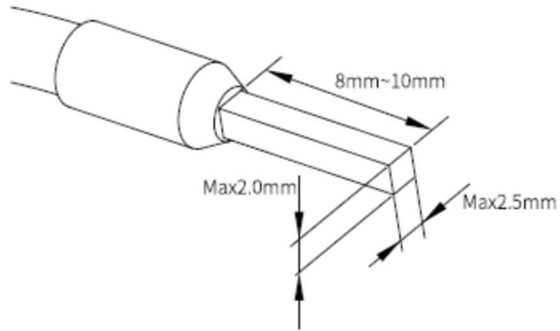

Standard cable crimper can be used for pressing the wire ear, as shown in the following figure:

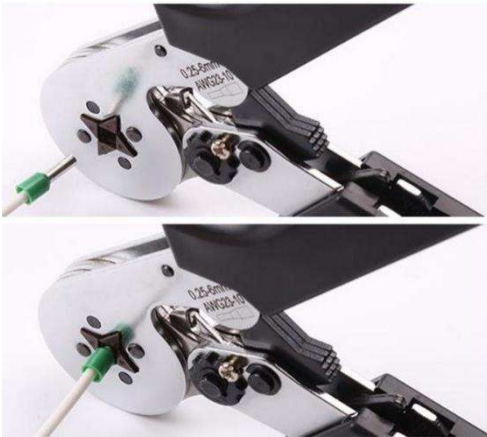

The wire connection does not need tools, and the wiring method is as follows:

- 1) Install the wire ear on the wire;
- 2) Insert the wire installed with the wire ear into the plug-in terminal to its most;
- 3) Pull the cable to ensure its fixed securely.

To release the wire:

- 1) Press the terminal spring button with your hand or a flat screwdriver

Pull out the wire and release the button.



7.2. Modules wiring diagram

7.2.1. FX20 system power supply diagram

The FX20 series backplane 5VDC power supply is provided by the adapter, and IO power supply for function module needs to provide separately. Additionally, an auxiliary power supply module can provide a larger backplane power supply current. The power supply system diagram is as follows:

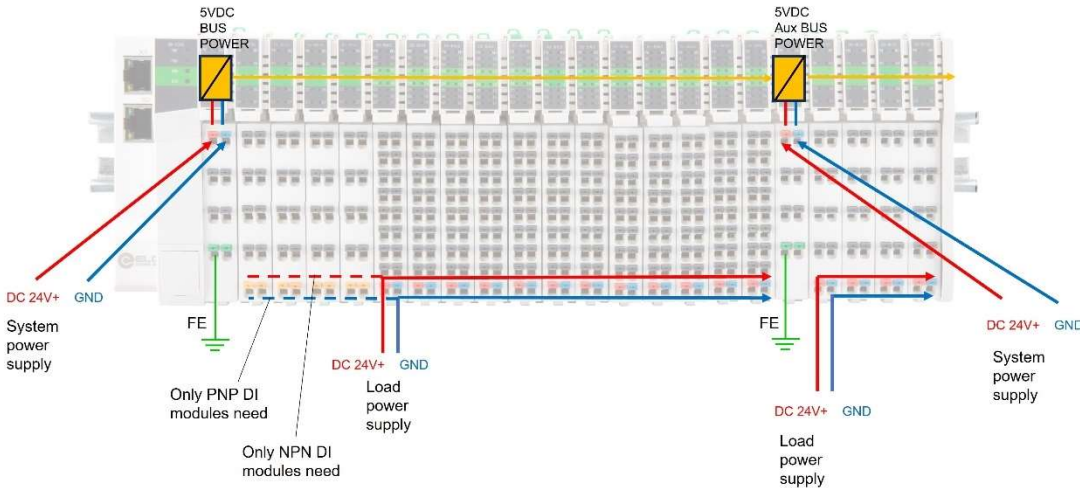

Warning!

- Be sure to disconnect all power connections before wiring!
- To ensure safety, must reliably connect the module grounding terminal to the ground!
- The wiring work must be operated by authorized electrical personnel to ensure safety!
- Using cables that do not meet the requirements will result in serious equipment damage or personal injury!

Please refer to this manual or the wiring diagram printed on the side of the module for wiring. Incorrect wiring will cause module damage or personal injury!

7.2.2. Definition of high-speed counting module terminals

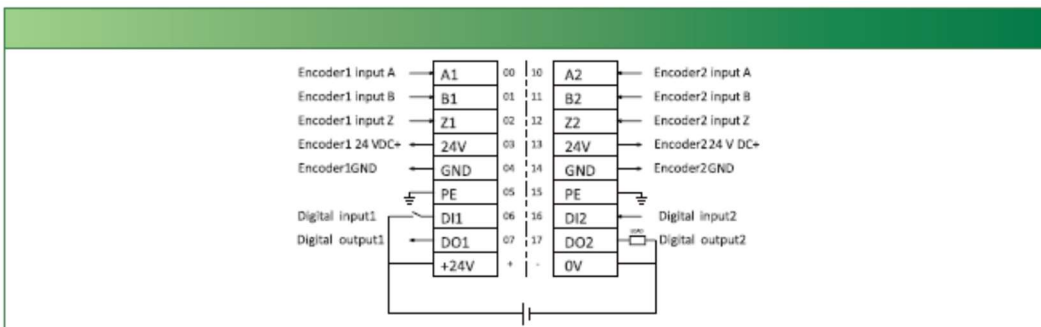

8. Configuration and debugging

8.1. Debugging in Siemens PORTAL

This section introduces the usage of the FX20 high-speed counting module through a configuration practical operation process.

This example uses ELCO's FX20 modular I/O system as the PROFINET slave station, and connects to Siemens PLC CPU1211C through the PROFINET bus. By default, all power supply and bus connections have been completed, and the device name of the FX20 coupler module is set to "fx gateway".

The minimum firmware version for using the ELCO FX20 PROFINET adapter in conjunction with the high-speed counting module is A692.

The list of selected products is as follows:

Model	Description	Quantity
FX20-GW-PN00	FX20 PROFINET adapter	1
FX20-CNT-BB00	Dual channel high-speed counting module	1

8.1.1. Configuration steps

8.1.1.1. Create a new Portal project

Open the TIA software, click "Create New Project", change the "Project Name" to FX20, select the save path, and click "Create".



8.1.1.2. Install the GSD file for FX20 products, refer to the relevant content in the FX20 Series modular I/O system PROFINET User Manual for specific methods.

8.1.1.3. Double clicks on "Add New Device" on the left and select the PLC model to use in the "Controller" window.

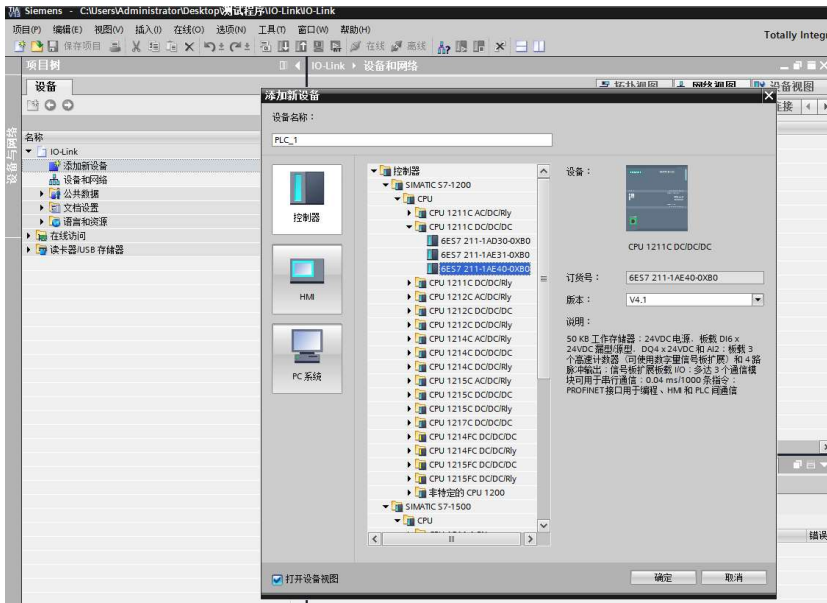

8.1.1.4. Double clicks on the "Device Configuration" window on the left, select "Properties" ->"PROFINET Interface [X2]" ->"Ethernet Address" in the "Device View" window, and set the IP address of the PLC.

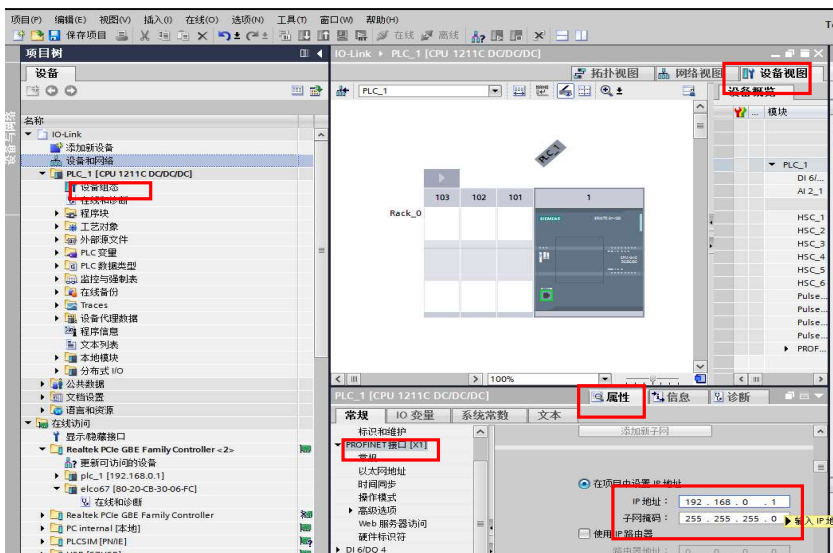

8.1.1.5. Add FX20 coupler module and communicate with PLC.

- 1) Double clicks on "Devices and Networks" on the left to enter the "Network View" interface. Select the FX20-GW-PN00 coupler for "Other Field Devices -->PROFINET IO -->I/O -->ELCO -->FX20" from the "Hardware Catalog", and double-click or drag to add it to the network.

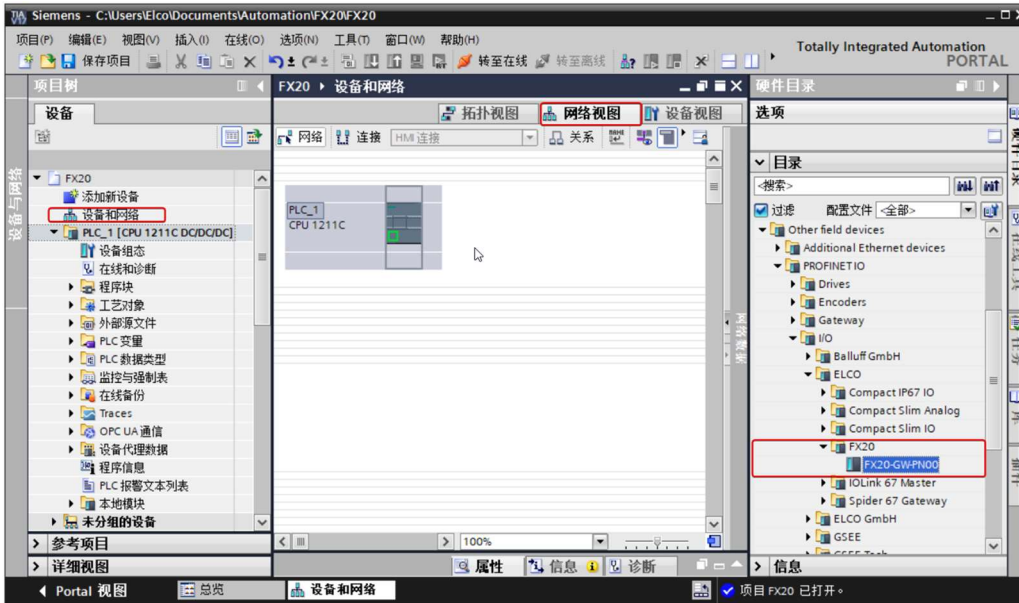

2) Click "Unassigned" with the mouse and select "PLC_2. PROFINET interface_2".

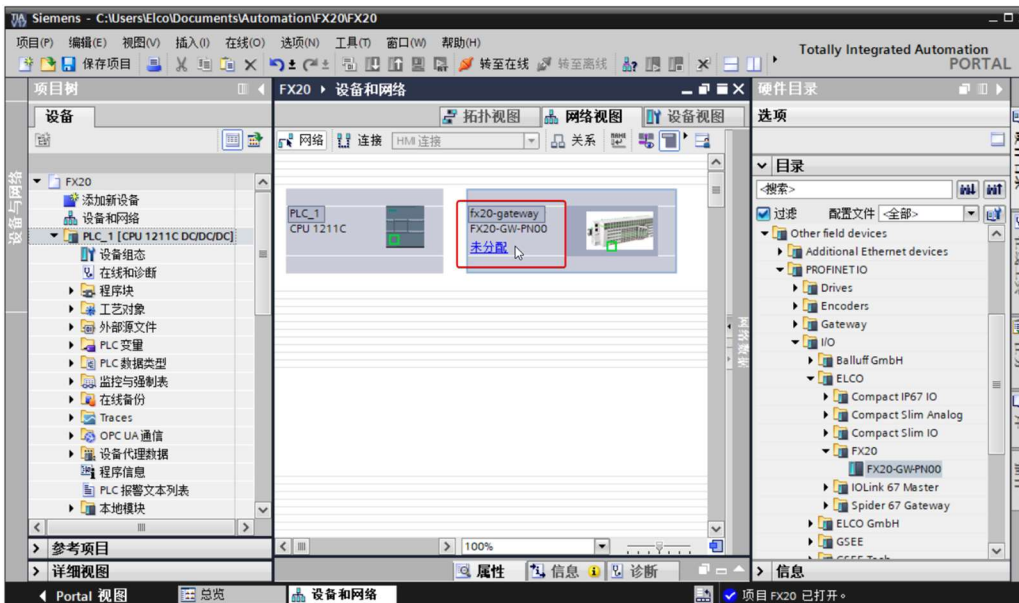

3) The FX20 coupler module is connected to the PLC for communication.

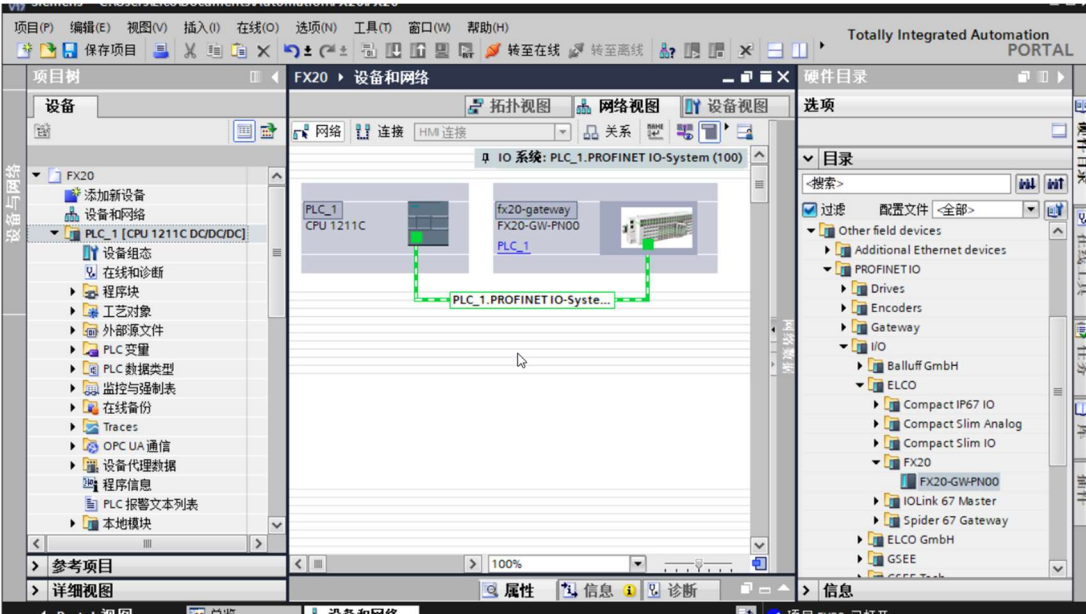

8.1.1.6. Modify the device name and IP address settings of the FX20 coupler module.

- 1) Click on the FX20 coupler module in the "Network View", select "Properties -->PROFINET Interface -->Ethernet Address", set the FX20 coupler module device name fx20 gateway in the window, and set the IP address. (Should be in the same network segment as the IP address of the PLC).

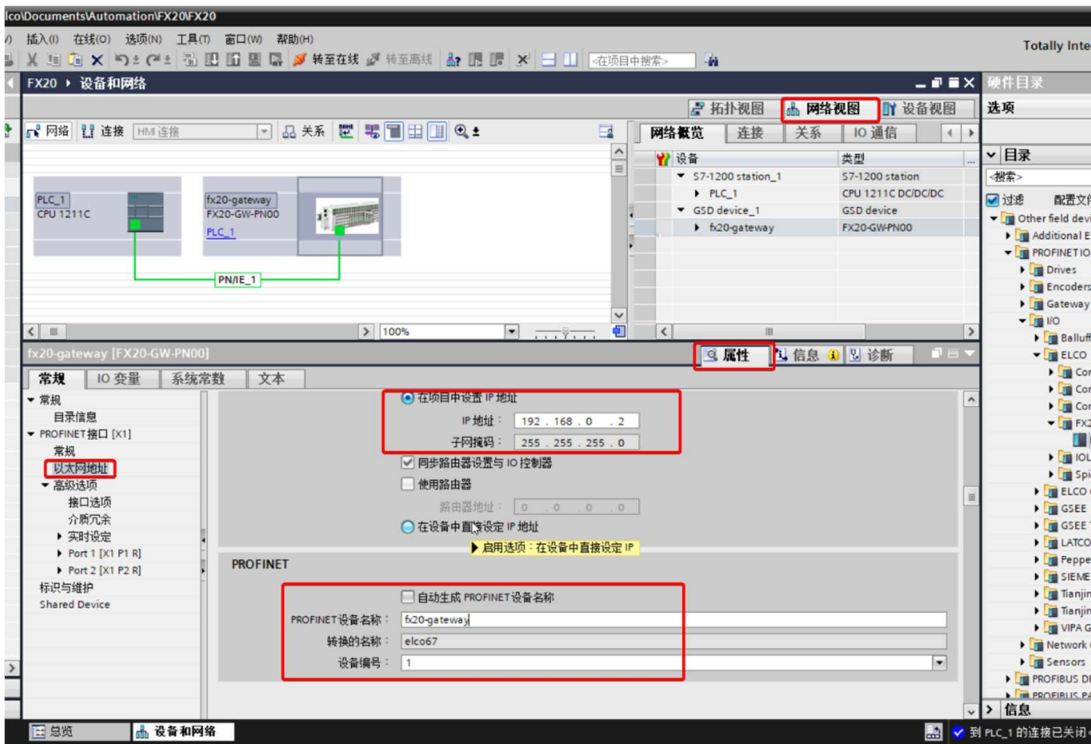

- 2) Select FX20-GW-PN00, right-click on the menu and select "Assign Device Name". In the interface for assigning PROFINET device names, click "Update List". At this time, the name and MAC address of the FX20 coupler module connected will be scanned. Select the device whose MAC address matches and

click "Assign Name".

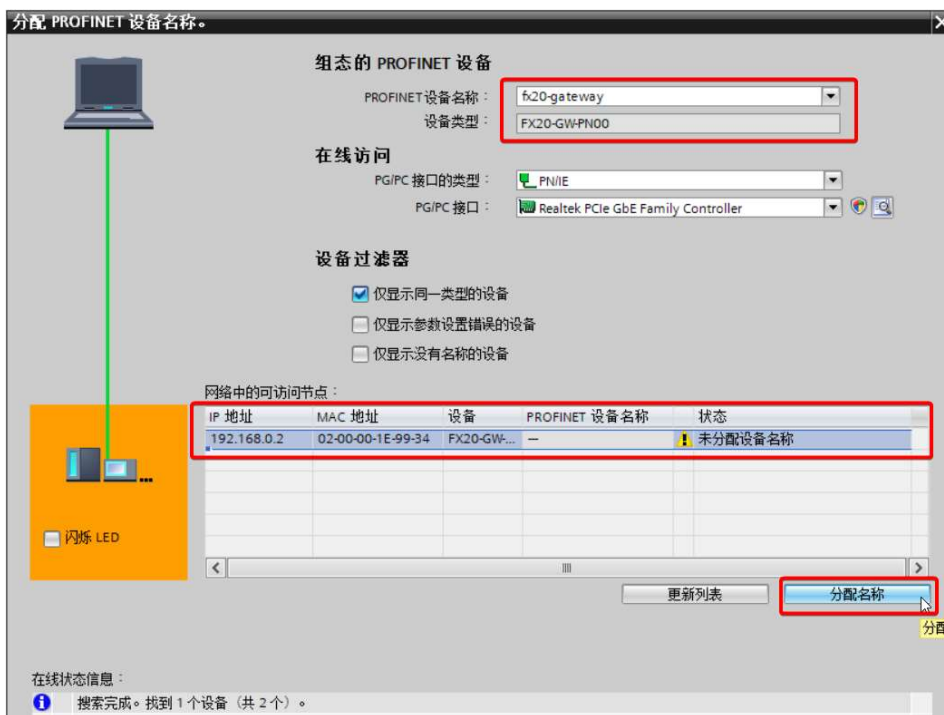
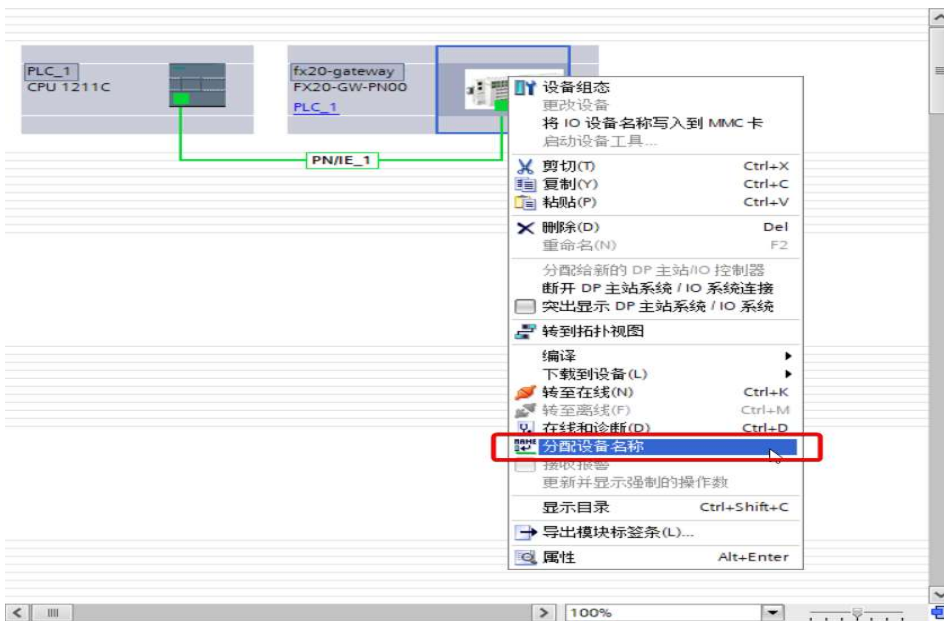

8.1.1.7. Add the corresponding model of plug-in I/O module in the "Device Overview", select "Module -->Function Modules -->FX20-CNT-BB00" module in the "Hardware Catalog" window, and drag it to the corresponding slot.

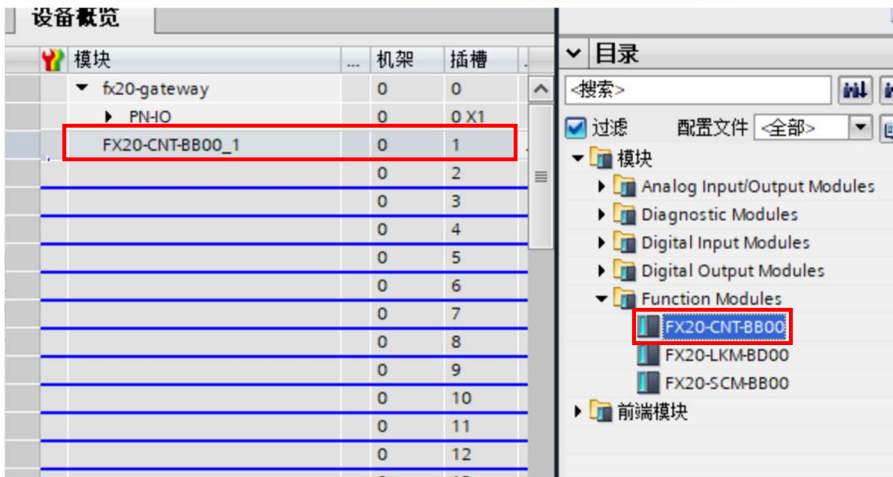

Tip: In this example, the high-speed counter inputs address 1-28; Output addresses 1-20 (input/output addresses can be modified as needed).

PN-IO	0	0 X1		
FX20-CNT-BB00_1	0	1	1...28	1...20
	0	2		

8.1.1.8. Select "FX20-CNT-BB00" ->"Properties" ->"Module Parameters" for parameter settings. Taking channel 1 as an example, the setting method for channel 2 is consistent with this.

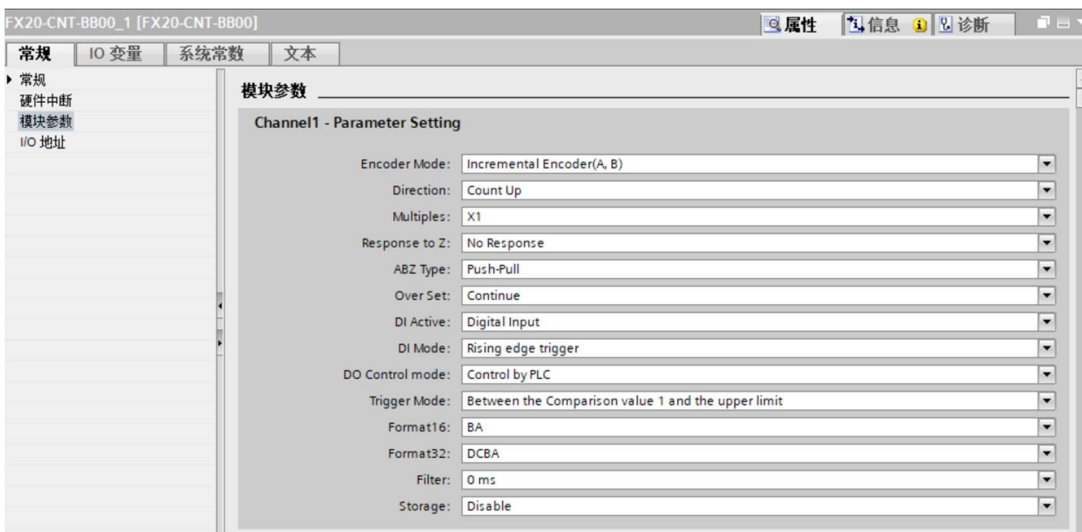

The meanings of each parameter are explained as follows:

1) Encoder Mode: Default incremental encoder (A,B) mode

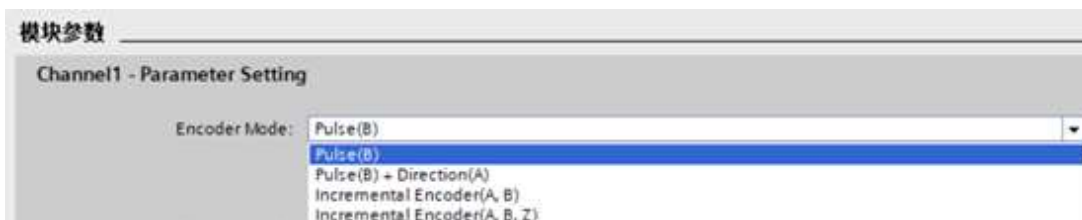

- a) Pulse B mode, only supports x1 frequency multiplication;
- b) Pulse B, direction A, only supports x1 frequency multiplication;
- c) AB incremental encoder mode, supporting x1/x2/x4 frequency multiplication;

d) ABZ incremental encoder mode, supporting x1/x2/x4 frequency multiplication.

2) Direction: Counting direction, defaults to count up



- a) Count Up;
- b) Count Down.

3) Multiples: Frequency multiplication setting



- a) X1: 1 Multiplication;
- b) X2: 2 Multiplication;
- c) X4: 4 Multiplication.

4) Response to Z: Z-mode setting: default no response



- a) No response;
- b) Synchronize.

5) ABZ Type: ABZ signal input type

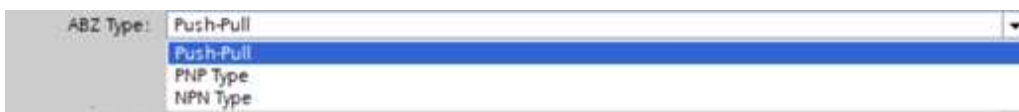

- a) Push-pull type;
- b) PNP type;
- c) NPN type.

6) Over Set: Configure calculation mode



- a) Continue;
- b) Stop.

7) DI Active: Input detection function, default normal IO input



- a) Digital Input;
- b) Pulse Capture.

8) DI Mode: DI mode, default rising edge triggered

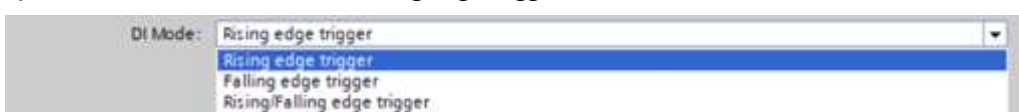

- a) Rising edge trigger;

- b) Falling edge trigger;
- c) Rising/ Falling edge trigger;

9) DO Control Mode: DO control mode, default controlled by PLC



- a) Control by PLC;
- b) Control by Module;

10) Trigger Mode

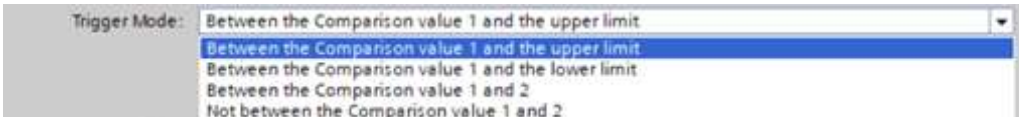

- a) Between the Comparison value 1 and the upper limit;
- b) Between the Comparison value 1 and the lower limit;
- c) Between the Comparison value 1 and 2;
- d) Not between the Comparison value 1 and 2;

11) Format16: Data format settings, default BA

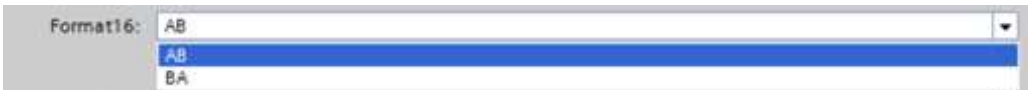

- a) AB;
- b) BA;

12) Format32: Data format settings, default DCBA



- a) ABCD
- b) CDAB
- c) BADC
- d) DCBA

13) Filter: Filter setting, default 0ms

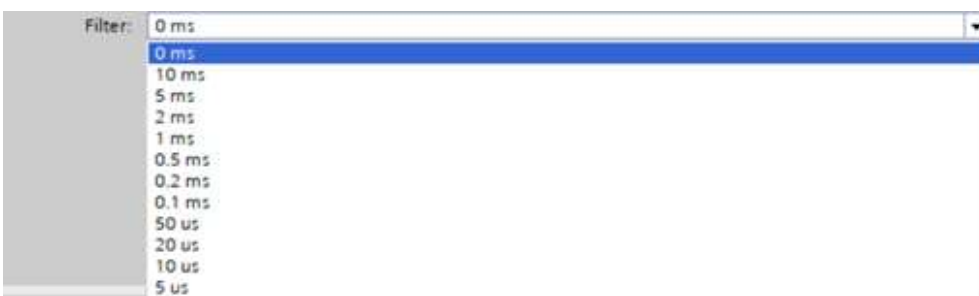

14) Storage Counter storage function, default disable



- a) Disable;
- b) Enable;

15) Measure Mode: Configure counter calculation mode, default to Frequency Synchronize measurement mode

If you need to modify it to "Speed", you need to modify the "Encoder Resolution" value based on the encoder's own

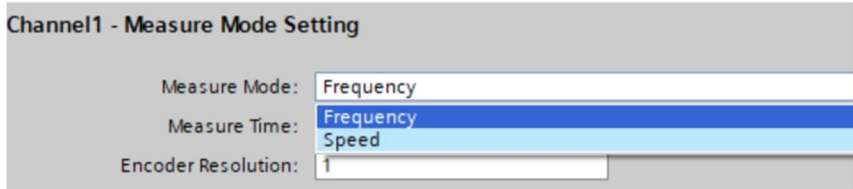

resolution; For example, if the encoder resolution is 2000, modify the Encoder Resolution value to 2000.

16) Measure time: Calculation cycle, default to 1000ms

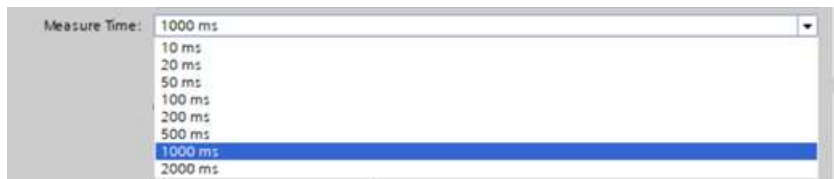

17) Encoder Resolution: Encoder resolution, default value is 1, range of values from 1 to 65535, to be filled in according to the encoder resolution value used.

18) Upper limit value: Count upper limit value, default to 2147483647

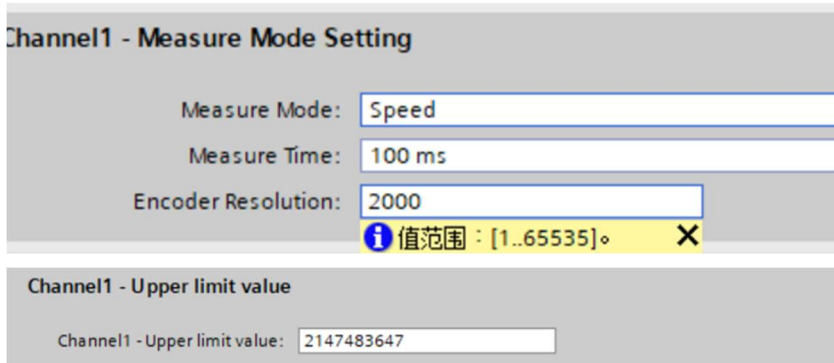

19) Initial value: Count initial value, default to 0, value range -2147483648... +2147483647



20) Comparison_value1: Count comparison value 1, default to 0, value range -2147483648 ... +2147483647



21) Comparison_value2: Count comparison value 1, default to 0, value range -2147483648... +2147483647



The setting method for Channel2 is completely consistent with Channel1 and will not be repeated.

8.1.1.9. After completing the parameter settings and saving the compilation, download the configured configuration to the PLC to complete the configuration work.

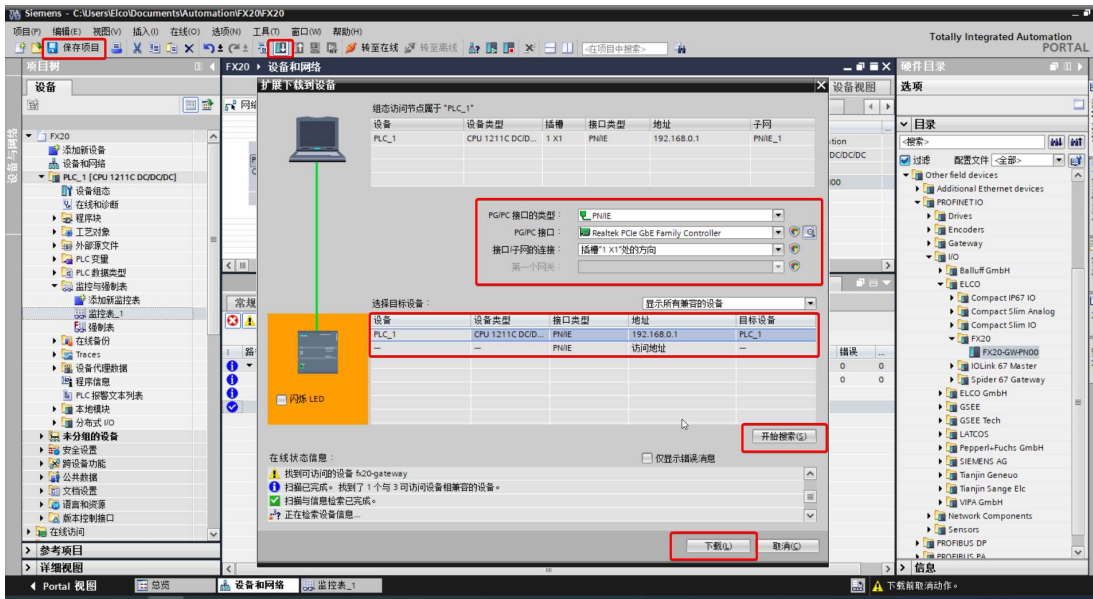

8.1.1.10. If everything is configured correctly at this time, the indicator lights of the FX20 coupler will be displayed in green, and the MD light of the serial communication module will be displayed in green and remain on.

9. Fault diagnosis

Item	Status	Meaning	Handling suggestions
High-speed counting module indicator lights			
PW	Green	Normal	None
	Off	Abnormal auxiliary power supply	<ol style="list-style-type: none"> 1. Check if the high-speed counting module is connected to auxiliary power supply; 2. Check whether the polarity of the auxiliary power supply is correct; 3. The module is damaged and needs to be replaced.
	Red	Abnormal 24VDC power supply	<ol style="list-style-type: none"> 1. Check whether the 24V auxiliary power supply of the module is overvoltage; 2. Check if the 24V auxiliary power supply of the module is under voltage; 3. The module is damaged and needs to be replaced.
MD	Green	Normal	None
	Green flashing	Connected, but not configured	<ol style="list-style-type: none"> 1. Check if the PLC configuration is complete; 2. Check if the module configuration is correct;
	Red/ green flashing	Not connected	<ol style="list-style-type: none"> 1. Check if the gold finger connection between modules is reliable; 2. Check if the left and right modules of the module are connected properly; 3. Restart the power supply of FX20.
	Red	Counter error	<ol style="list-style-type: none"> 1. Check if the module count parameters are correct; 2. Check if there is a short circuit or overload in the module; 3. Module damaged, replace it.
EN1, EN2	Green	Channel1 or 2 Enable	None
	Off	Disable	None
A1, B1, Z1 A2, B2, Z2	Green	With signal input	None
	Off	No signal input	Check the encoder cable connection
UP	Green	Upward Count	-
	Off	-	-
DN	Green	Downward Count	-
	Off	-	-
DI	Green	DI on	-
	Off	DI off	-
DO	Green	DO on	-
	Off	DO off	-

Appendix

Description of configuration data and process data

1. Configuration parameters

1.1. Configuration Data Description

No	Type	Description	Data length
1	Control register 1	Refer to 1.3	31bytes
2	Control register 2	Refer to 1.5	31bytes

1.2. Channel 1 configuration parameters

No.	Index	Subindex	Parameters	Description
1	0x3000	0x01	Encoder control register	Form 1.3 BYTE1-4
2		0x02	Encoder calculation control register	Form 1.3 BYTE5-7
3		0x03	Transmission ratio setting	Form 1.3 BYTE8-11
4		0x04	ch1_value_max	Form 1.3 BYTE12-15
5		0x05	ch1_value_reset	Form 1.3 BYTE16-19
6		0x06	ch1_value_min	Form 1.3 BYTE20-23
7		0x07	ch1_comparison_value1	Form 1.3 BYTE24-27
8		0x08	ch1_comparison_value2	Form 1.3 BYTE28-31

1.3. Channel 1 Control Register Description

No.	Bit7	Bit6	Bit5	Bit4	Bit3	Bit2	Bit1	Bit0
1	ch1_Z_set	ch1_multiples		ch1_dir		ch1_encoder_mode		
2	res	ch1_over_set	ch1_ABZ_type		ch1_di_enable	ch1_di_mode		
3	res	ch1_do_control	-		ch1_trigger_mode			
4	ch1_storage	ch1_format32		ch1_format16	ch1_filter			
5	res		ch1_measur_mode		ch1_measur_time			
6	ch1_encoder_resolution_h							
7	ch1_encoder_resolution_l							
8	ch1_measur_ratio_master_h							
9	ch1_measur_ratio_master_l							
10	ch1_measur_ratio_slave_h							
11	ch1_measur_ratio_slave_l							
12	ch1_value_max_4							
13	ch1_value_max_3							
14	ch1_value_max_2							
15	ch1_value_max_1							
16	ch1_value_reset_4							
17	ch1_value_reset_3							
18	ch1_value_reset_2							
19	ch1_value_reset_1							
20	ch1_value_min_4							
21	ch1_value_min_3							

22	ch1_value_min_2
23	ch1_value_min_1
24	ch1_comparison_value1_4
25	ch1_comparison_value1_3
26	ch1_comparison_value1_2
27	ch1_comparison_value1_1
28	ch1_comparison_value2_4
29	ch1_comparison_value2_3
30	ch1_comparison_value2_2
31	ch1_comparison_value2_1

1.4. Channel 2 configuration parameters

No.	index	subindex	Parameters	Description
1	0x3000	0x01	Encoder control register	Form 1.5 BYTE1-4
2		0x02	Encoder calculation control register	Form 1.5 BYTE5-7
3		0x03	Transmission ratio setting	Form 1.5 BYTE8-11
4		0x04	ch2_value_max	Form 1.5 BYTE12-15
5		0x05	ch2_value_reset	Form 1.5 BYTE16-19
6		0x06	ch2_value_min	Form 1.5 BYTE20-23
7		0x07	ch2_comparison_value1	Form 1.5 BYTE24-27
8		0x08	ch2_comparison_value2	Form 1.5 BYTE28-31

1.5. Channel 2 Control Register Description

No.	Bit7	Bit6	Bit5	Bit4	Bit3	Bit2	Bit1	Bit0
1	ch2_Z_set	ch2_multiples		ch2_dir		ch2_encoder_mode		
2	res	ch2_over_set	ch2_ABZ_type		ch2_di_enable	ch2_di_mode		
3	res	ch2_do_control	-		ch2_trigger_mode			
4	ch2_storage	ch2_format32		ch2_format16	ch2_filter			
5	res		ch2_measur_mode		ch2_measur_time			
6	ch2_encoder_resolution_h							
7	ch2_encoder_resolution_l							
8	ch2_measur_ratio_master_h							
9	ch2_measur_ratio_master_l							
10	ch2_measur_ratio_slave_h							
11	ch2_measur_ratio_slave_l							
12	ch2_value_max_4							
13	ch2_value_max_3							
14	ch2_value_max_2							
15	ch2_value_max_1							
16	ch2_value_reset_4							
17	ch2_value_reset_3							
18	ch2_value_reset_2							

19	ch2_value_reset_1
20	ch2_value_min_4
21	ch2_value_min_3
22	ch2_value_min_2
23	ch2_value_min_1
24	ch2_comparison_value1_4
25	ch2_comparison_value1_3
26	ch2_comparison_value1_2
27	ch2_comparison_value1_1
28	ch2_comparison_value2_4
29	ch2_comparison_value2_3
30	ch2_comparison_value2_2
31	ch2_comparison_value2_1

1.6. Configuration parameter description

- ch(1,2)_Z_set:Z mode set, default 0
 - 0- No response;
 - 1- Synchronization;
- ch (1,2) _multiples: Frequency multiplication setting, default value 0
 - 0- ×1
 - 1- ×2
 - 2- ×4
- ch(1,2)_Dir: Counting direction, default 01
 - 01- Upward
 - 10-Downward
- ch (1,2) _Dir: Counting mode configuration, default value 011
 - 001- Pulse B mode, only x1 Frequency multiplication;
 - 010- Pulse B, direction A, only x1 Frequency multiplication;
 - 011- Incremental encoder AB mode, support x1/ x2/ x4 FM;
 - 100- Incremental encoder ABZ mode, support x1/ x2/ x4 FM.
- ch (1,2) _2) _ calculation mode, default 0
 - 0- Continue counting;
 - 1- Stop counting;
- ch (1,2) _2) _ input type settings
 - 00- Push-pull
 - 01- PNP
 - 02- NPN
- ch (1,2) _2) _ detection function, default 0
 - 0- Normal IO input;
 - 1- Pulse capture function;
- ch(1,2)_di_mode:DI mode, default 000
 - 000- Rising edge trigger;

- 001- Falling edge trigger;
- 002- Edge trigger;
- ch(1,2)_do_control:DO control mode, default 0
 - 0- Controlled by PLC;
 - 1- Controlled by module;
- ch (1,2) _dismoded mode configuration, default 0000
 - 0000- Between comparison_value1 and maximum value;
 - 0001- Between the minimum value and comparison_value1;
 - 0010- Between comparison value 1 and comparison value 2;
 - 0011- Not between comparison value 1 and comparison value 2;
- ch (1,2) _storage: Counting value storage function, default 0
 - 0- Not stored;
 - 1- Stored;
- ch (1,2) _format32:32-bit data format setting, default to 03
 - 00- ABCD
 - 01- CDAB
 - 02- BADC
 - 03- DCBA
- ch (1,2) _format16:16-bit data format setting, default to 1
 - 0- AB
 - 1- BA
- ch(1,2)_filter:Filter settings, default 0
 - 0- 0ms
 - 1- 10ms
 - 2- 5ms
 - 3- 2ms
 - 4- 1ms
 - 5- 500μs
 - 6- 200μs
 - 7- 100μs
 - 8- 50μs
 - 9- 20μs
 - 10- 10μs
 - 11- 5μs
- ch (1,2) _measur_mode: Configure calculation mode, default 01
 - 01- Frequency;
 - 02- Speed;
- ch (1,2) _measur_time: Calculation cycle, default 0110
 - 0000- 10ms;
 - 0001- 20ms;
 - 0010- 50ms;
 - 0011- 100ms;

- 0100- 200ms;
- 0101- 500ms;
- 0110- 1000ms;
- 0111- 2000ms;
- ch(1,2)_encoder_resolution_h、 ch(1,2)_encoder_resolution_l: Sensor resolution, default value 1
Input range:1 ~ 65535;
- ch(1,2)_measur_ratio_master_h、 ch(1,2)_measur_ratio_master_l: Configure measure master conversion ratio, default value 1
Input range:1 ~ 65535;
- ch(1,2)_measur_ratio_slave_h、 ch(1,2)_measur_ratio_slave_l: Configure measure slave conversion ratio, default value 1;
Input range:1 ~ 65535;
- ch (1,2) _value_max (4-1): Count upper limit value, default value 2147483647
Input range:-2147483648 ~ 2147483647;
- ch (1,2) _value_reset (4-1): Initial value of count value, default value 0
Input range:-2147483648 ~ 2147483647;
- ch (1,2) _value_min (4-1): Count lower limit value, default value -2147483648
Input range:-2147483648 ~ 2147483647;
- ch (1,2) _comparison_value1(4-1): Count comparison value 1, default value 0
Input range:-2147483648 ~ 2147483647;
- ch (1,2) _comparison_value2(4-1): Count comparison value 2, default value 0
Input range:-2147483648 ~ 2147483647;

2. Process Data Description

2.1. Input Data

No.	Register Name	Register Description	Description	Data format	Data length
1	status	Status register	Refer to form 2.2	-	4bytes
2	ch1_count	Channel 1 Counting Value	Pulse count value for channel 1	int	4bytes
3	ch1_capture	Channel 1 capture value	When DI is triggered, the pulse count value	int	4bytes
4	ch1_measured	Channel 1 measurement value	Display conversion results based on configuration information	float	4bytes
5	ch2_count	Channel 2 Counting Value	Pulse count value for channel 2	int	4bytes
6	ch2_capture	Channel 2 capture value	When DI is triggered, the pulse count value	int	4bytes
7	ch2_measured	Channel 2 measurement value	Display conversion results based on configuration information	float	4bytes

2.2. Input Status Register Description

No.	Bit7	Bit6	Bit5	Bit4	Bit3	Bit2	Bit1	Bit0
1	ch1_sync	ch1_cap	ch1_cns	ch1_DI	ch1_up	ch1_down	ch1_over	ch1_under
2	ch2_sync	ch2_cap	ch2_cns	ch2_DI	ch2_up	ch2_down	ch2_over	ch2_under
3	suppower	res			res	res	res	ch1_ld_error
4	syspower	res			res	res	res	ch2_ld_error

- chx_sync: Indicates whether the current count loads the initial value through an external reference signal
0- Not loaded;
1- Loaded;
- chx_cap: Indicates whether the current count (capture) is updated
0- Not Updated;
1- Updated;
- chx_cns: Indicates the counting status of the current channel within 0.5 seconds
0- No count;
1- Counted;
- chx_DI: Indicates the current channel input signal status
0- Low level;
1- High level;
- chx_up: Display the current channel count up status
1- Upward counting;
- chx_down: Display the current channel count down status
1- Downward counting;
- chx_over: Determine whether the current count has caused an upward overflow;
0- No overflow,
1- Overflow;
- chx_under: Determine whether the current count has caused a downward overflow;
0- No overflow;

- 1- Overflow;
- suppower: External voltage overvoltage and undervoltage alarm;
- syspower: System voltage overvoltage or undervoltage alarm;
- chx_ld_error: Encoder error indication, not meeting the following conditions:
 - Lower limit value ≤ counter value ≤ upper limit value;
 - Lower limit value ≤ initial value ≤ upper limit value;
 - Lower limit value ≤ Comparison value 1 ≤ upper limit value;
 - Lower limit value ≤ Comparison value 2 ≤ upper limit value;
- Ch (1、2) _count: Current encoder count value;
- Ch (1、2) _di_count: Count value when DI is triggered;
- Ch (1、2) _measured: Converted value.

2.3. Output data

No.	Register	Description	Data format	Data length	
1	control	Control register	See Form 2.4	4bytes	
2	ch1_slot1	Channel 1 loading value 1	Channel 1 loading value 1	int	4bytes
3	ch1_slot2	Channel 1 loading value 2	Channel 1 loading value 2	int	4bytes
4	ch2_slot1	Channel 2 loading value 1	Channel 2 loading value 1	int	4bytes
5	ch2_slot2	Channel 2 loading value 2	Channel 2 loading value 2	int	4bytes

2.4. Output Status Control Register Description

No.	Bit7	Bit6	Bit5	Bit4	Bit3	Bit2	Bit1	Bit0
1	ch1_tv_set		ch1_DO	ch1_clear	ch1_DO_enable	ch1_DI_enable	ch1_enbale	
2	ch2_tv_set		ch2_DO	ch2_clear	ch2_DO_enable	ch2_DI_enable	ch2_enbale	
3	ch1_ld_slot2			ch1_ld_slot1				
4	ch2_ld_slot2			ch2_ld_slot1				

- ch (1,2) _tv_set: Trigger value setting, default 01
 - 01- comparison_value1 is upper limit value, comparison_value2 is Lower limit value;
 - 10- comparison_value2 is upper limit value, comparison_value1 is Lower limit value;
- ch(1,2)_DO:DO output, default 00
 - 00- Off;
 - 01- On;
- ch (1,2) _clear: Clear overflow flag
 - 0- Disable;
 - 1- Enable;
- ch(1,2)_DO_enable: DO enable setting, default 0
 - 0- Disable;
 - 1- Enable;
- ch (1,2) _DI_enable: DI input capture function setting, default 0
 - 0- Disable;
 - 1- Enable;
- ch (1,2) _enable: Encoder enable configuration, default 0
 - 0- Stop;

- 1- Start counting;
- ch (1,2) _ld_slot (1,2): Set encoder trigger value
 - 0000- No response;
 - 0001- Load Count Values;
 - 0010- Reserved;
 - 0011- Load Initial Values;
 - 0100- Load Comparison Value 1;
 - 0101- Load Comparison Value 2;
 - 0110- Load Count Lower Limit;
 - 0111- Load Count Upper Limit;
 - 1000 ~ 1111-Reserved;
- ch (1,2) _slot (1,2): Set encoder range value
 - Input Range:-2147483648 ~ 2147483647.